

# **HEDSTROM**<sup>®</sup>

**FIT FOR LIFE**

## **12FT All in One Trampoline - M008622** **FOR CHILDREN AGED 3+**



MV Sports & Leisure Ltd.  
35 Tameside Drive  
Castle Bromwich B35 7AG  
United Kingdom

[www.mvsports.com](http://www.mvsports.com)

### **CUSTOMER SERVICES**

MV has taken great care to ensure that this item has reached you in good condition. Should you have a query, please contact: [customer.services@mvsports.com](mailto:customer.services@mvsports.com) where your query will be dealt with promptly. Alternatively, you can call on 0121 748 8017.

**Made in China**



**Vulcan Consulting**  
EU Authorised Representative, The Merriion  
Buildings - Iconic offices, 18-20 Merriion  
Street, Dublin 2, D02 XH38, Ireland.

This mark denotes compliance with the standards laid down by the E.C. (European Community)

It is in your best interest to keep a note of our name and address for future reference. If you have any complaints or find this product to be faulty, in order to avoid any delay, please contact the distributor at the address shown below.

# SAFETY INSTRUCTIONS

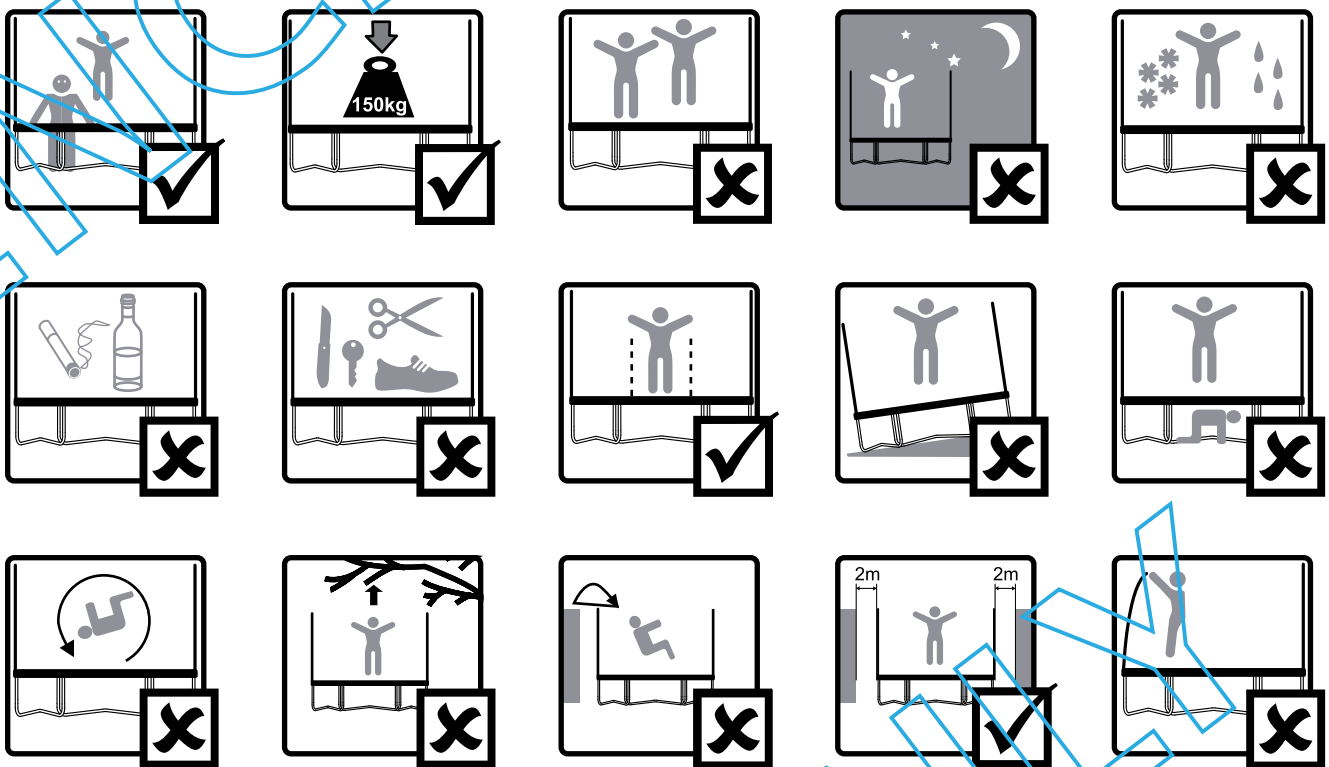

## WARNINGS!

Adult assembly required. 2 adults and approx. 1 hour required for assembly. Read the instructions before assembly.

Adult supervision required at all times.

Not suitable for children under 36 months, small parts, choking hazard.

Minimum user age 3 years. Maximum user age 12 years. Max user weight 150KG.

Only for domestic use. Outdoor use only.

This trampoline is not intended to be buried in the ground.

Do not modify the trampoline from its original design.

Only one user at a time, collision hazard.

Always ensure that the net is closed before use.

Remove shoes before use.

Do not use when wet. Do not use in strong wind conditions.

Empty pockets and hands before practice.

Always jump in the middle of the mat.

No somersaults. Do not eat while jumping.

Do not exit trampoline by jumping off it.

Limit the time of continuous use (take regular breaks).

The trampoline shall be assembled by an adult in accordance with the assembly instructions and thereafter checked before the first use.

It is important that you secure your trampoline during windy conditions. Move the trampoline to a sheltered area. Fixing kits are available to purchase. Please refer to website for details.

Must not be installed over concrete, asphalt or any other hard surface, nor at proximity of other conflicting installations (e.g. padding pools, swings, slide, climbing frames).

Place on a level surface at least 2m from any structure or obstruction, such as a fence, garage, house, overhanging branches, laundry lines or electrical wires.

FINALLY, PLEASE CHECK THAT ALL FASTENINGS ARE TIGHTENED SECURELY AND THAT THE NET IS TAUT. THIS CHECK SHOULD BE CARRIED OUT REGULARLY TO ENSURE CONTINUED SAFE USE OF THE ENCLOSURE

Some component parts, for example enclosure nets, will be subject to wear and tear and may need replacing during the lifetime of the product. It is important that you regularly check the trampoline and any associated equipment (e.g. enclosures) for damage. Failure to replace parts could affect the safety of the product. If you need a replacement part please contact the helpline located at the end of the safety instructions.

Do not pull the top of the enclosure net.

Do not intentionally bounce off the enclosure net. Deliberate jumping into or bouncing off the enclosure is potentially

### BEFORE EACH USE!

Inspect the trampoline for stability & any signs of wear and tear; this includes the springs, frame & fabric parts. Ensure that the frame is sound & stable and that all legs & fittings are securely in place. Check for holes, tears or loose stitching in the jump mat and if found the mat needs to be replaced. Trampoline should not be used if the jump mat is damaged. Ensure that the protective padding is correctly positioned to cover the springs and frame. Check for foreign objects or protrusions of any kind in the jump mat & pad. If you have an enclosure fitted (recommended) check for holes, tears and loose stitching; also check the function of zip & securing clips. If there is any damage, the trampoline should not be used.

### MONTHLY

If the mat is sagging, this is an indication that the springs are showing signs of wear and should be replaced. Also check for missing or broken springs.

All parts of the metal frame should be checked for signs of damage or wear of any kind; all affected parts must be replaced before the trampoline is used.

Retain assembly instructions for future use.

It is advised that on a regular basis (i.e. at the beginning of the season and monthly thereafter) all main parts/ fixings are checked as secure, well oiled (if metallic), have no sharp points/ edges and are intact. Replace, oil and/ or tighten when necessary. Failure to do so may result in an injury or hazard.

### RECOMMENDATIONS FOR ASSEMBLY AND MAINTENANCE

- Check all nuts and bolts and tighten when required
- Check that all spring-loaded (pit pin) joints are still intact and can not become dislodged during play.
- Check all coverings and sharp edges and replace when required.
- Retain the maintenance instruction manual.
- Outdoor trampolines should be equipped with a device that in strong wind conditions avoid displacement due to wind (e.g. steel bars in the ground or loads like sand bag or water bags) and / or items catching wind like net and mat should be removed.
- In certain countries during the winter period, snow loads and very low temperatures can damage the trampoline. It is recommended to remove any snow and store the mat and the enclosure indoors.
- Check that mat, padding and enclosure are without defects.
- Replace the net and / or enclosure after 1 year of use.
- Make sure that the hook-and-loop fastenings are closed correctly during use of trampoline.

Lay Out Parts like this

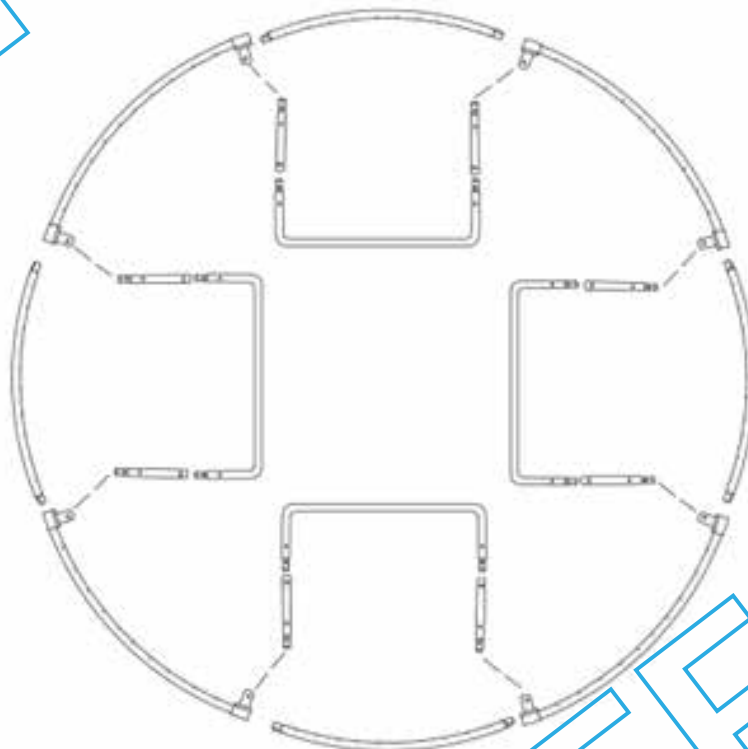

12/14 FT

# PARTS LIST

	<i>MODEL SIZE</i>	<i>12FT</i>
<i>A</i>	<i>FRAME TUBE-A</i>	<i>4</i>
<i>B</i>	<i>FRAME TUBE-B</i>	<i>4</i>
<i>C</i>	<i>COVER PADS</i>	<i>1</i>
<i>D</i>	<i>JUMPING MAT</i>	<i>1</i>
<i>E</i>	<i>LEG EXTENSION</i>	<i>8</i>
<i>F</i>	<i>LEG BASE</i>	<i>4</i>
<i>G</i>	<i>SPRINGS</i>	<i>72</i>
<i>H</i>	<i>SPRING TOOL</i>	<i>1</i>
<i>I</i>	<i>SCREWS</i>	<i>8</i>
<i>J</i>	<i>SCREW DRIVER</i>	<i>1</i>

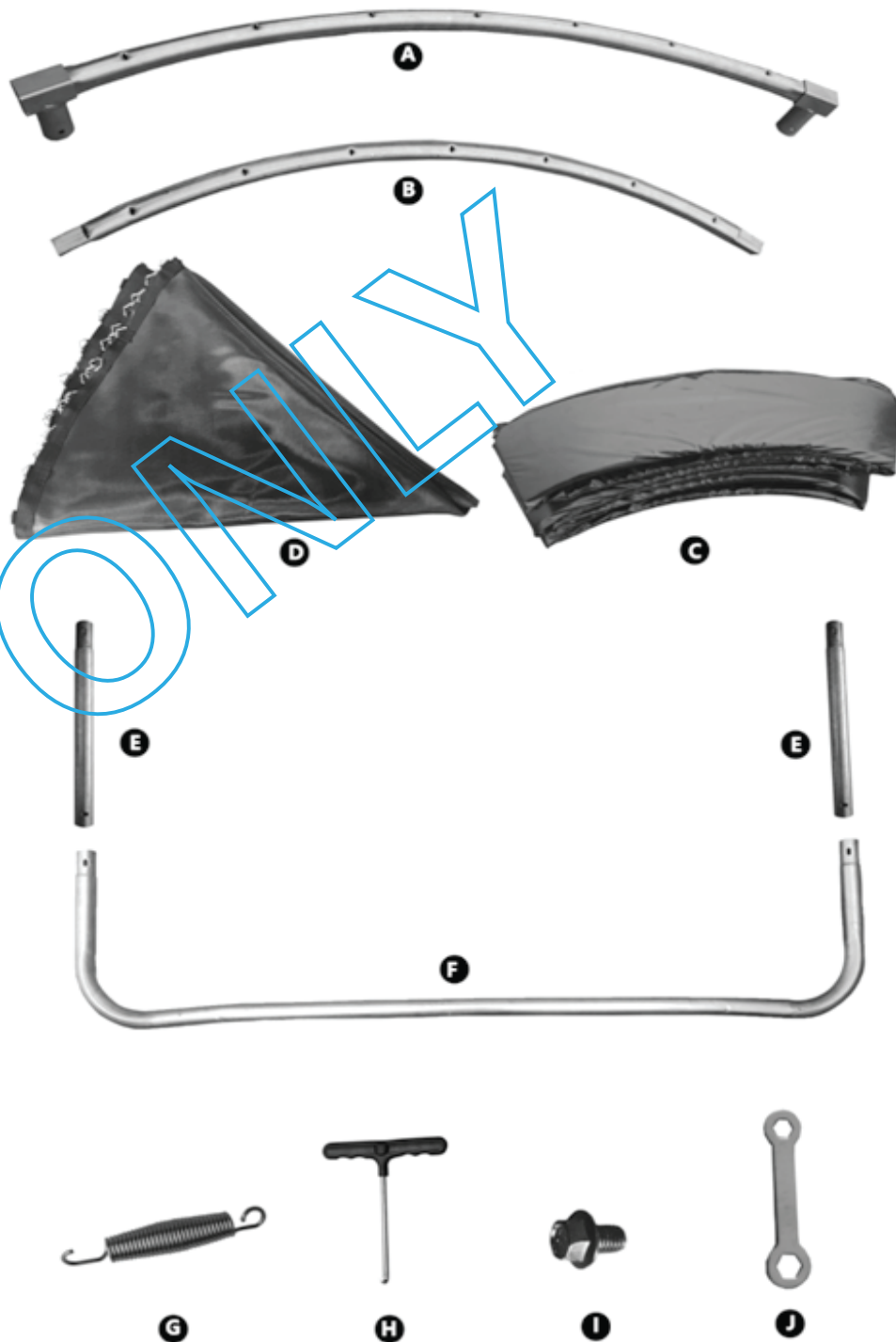

12FT Trampoline: leg extensions( Part E) included .

# ASSEMBLY INSTRUCTIONS

1

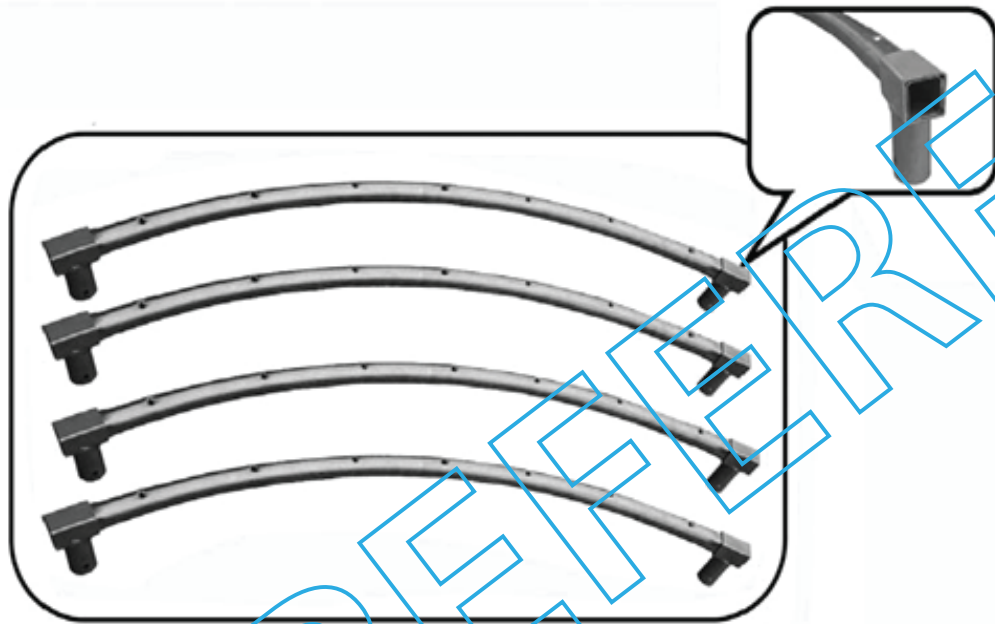

Attach all the T-connectors to the two ends of the frame tube (A). Ensure it is tightly secured before moving on .

2

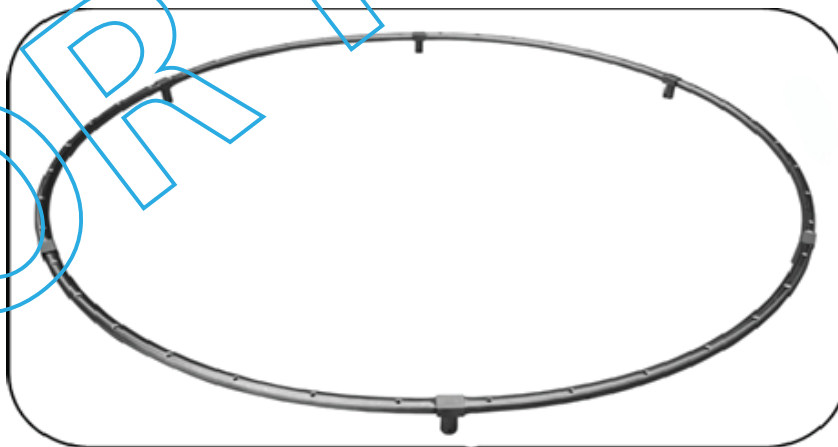

Connect all frame tubes (B) to the other frame tubes (A) to form a circle.  
Connecting of the last two parts may requires two people ; One to hold the other end of the frame whilst the other connects both ends to complete the circle .

3

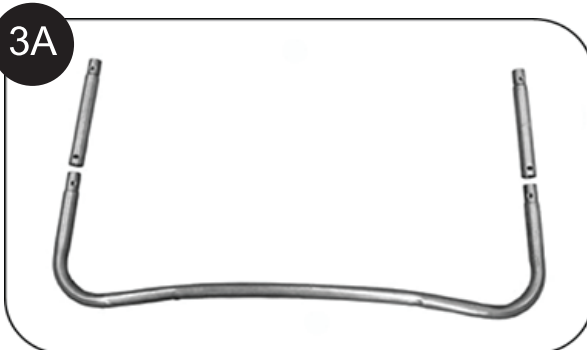

Attach the Leg extension (E) to a Leg base (F) and secure together with the Screws (I) and tighten.  
Repeat for all leg supports.

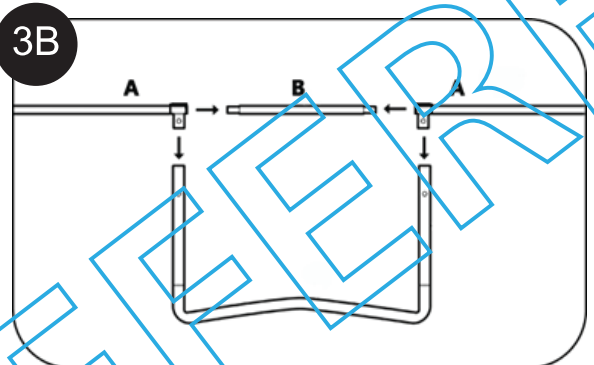

Attach the all leg supports to the top frame circle.  
For size 12FT ,assemble the T-connectors slots into the Leg extension (E).



## WARNING

PLEASE WEAR SAFETY GOGGLES WHEN ATTACHING THE SPRINGS,  
AS THEY MAY COME LOOSE DURING ASSEMBLY.

4

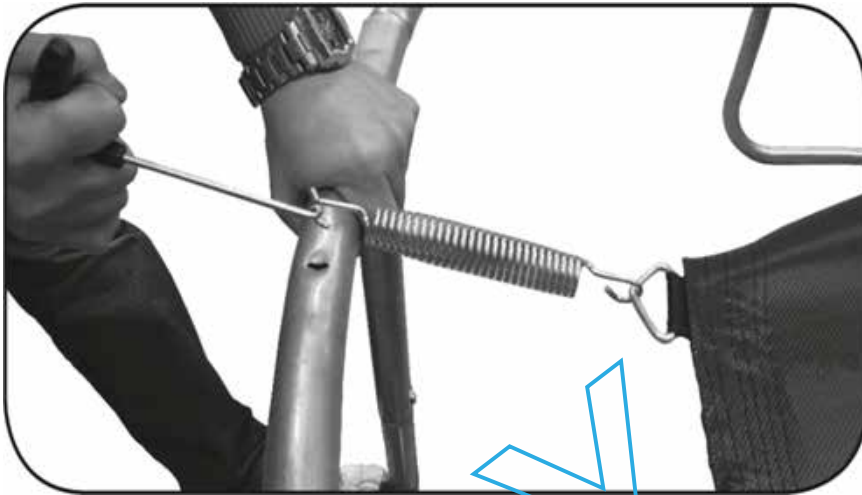

Attach the Springs (G) using the Spring tool (H). To make it easier, ensure the first two springs are installed opposite to each other so they sit parallel to each other on the base, then repeat the same process for the next two springs. After this the remaining spring can be installed.

5

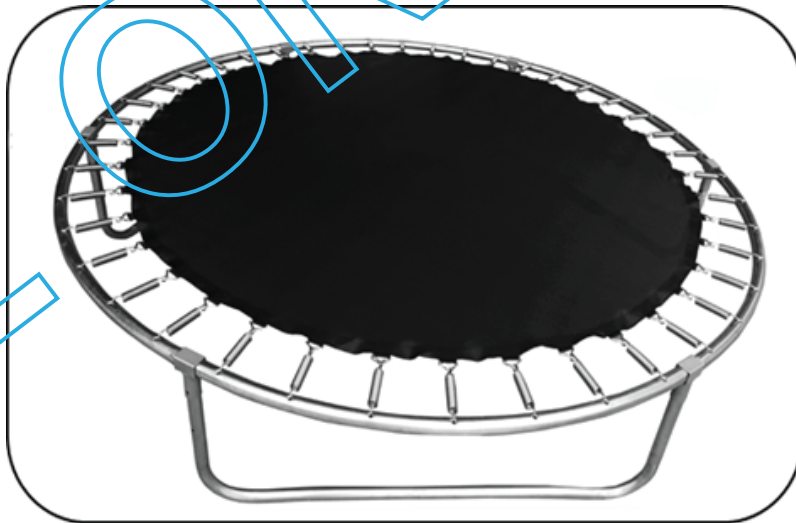

At this stage, the trampoline looks like this photo.

6



Place the Cover pads (C) for springs onto the trampoline so the springs are fully covered and fasten with rubber bands.

# SAFETY ENCLOSURE

## PARTS LIST

	<i>MODEL SIZE</i>	<i>12FT</i>
<i>K</i>	<i>LOWER POLE</i>	<i>8</i>
<i>L</i>	<i>UPPER POLE</i>	<i>8</i>
<i>M</i>	<i>SAFETY NET</i>	<i>1</i>
<i>N</i>	<i>QUICK CLAMP</i>	<i>16</i>
<i>O</i>	<i>QUICK CLAMP</i>	<i>--</i>
<i>J</i>	<i>SPANNER</i>	<i>1</i>



# SAFETY NET ASSEMBLY

1

Position the safety net parts as below:

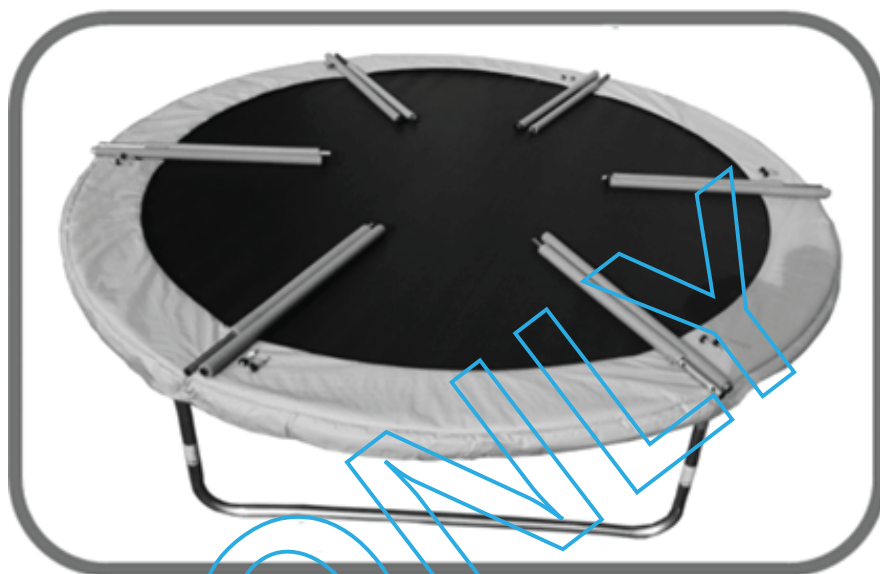

2



Assemble the Lower poles (K) to the leg base by using the Quick clamps (N) and tighten the nuts by Spanner (J).  
The Quick clamps (N) assembled on the upper and lower holes .

3

Once all of the lower poles (K) fixed, your trampoline looks like this picture





4



Fit the upper poles (L) by pushing them down to the readily assembled lower poles.:

5



Now you must fit the safety net (M). Place it on the trampoline on the inner side of the fitted poles. The zip must be at the bottom and point outwards.

6



Slide down the sleeves of the safety net to the poles.

7



Attach the hooks at the bottom of the safety net to the nearest triangle ring of the mat

8

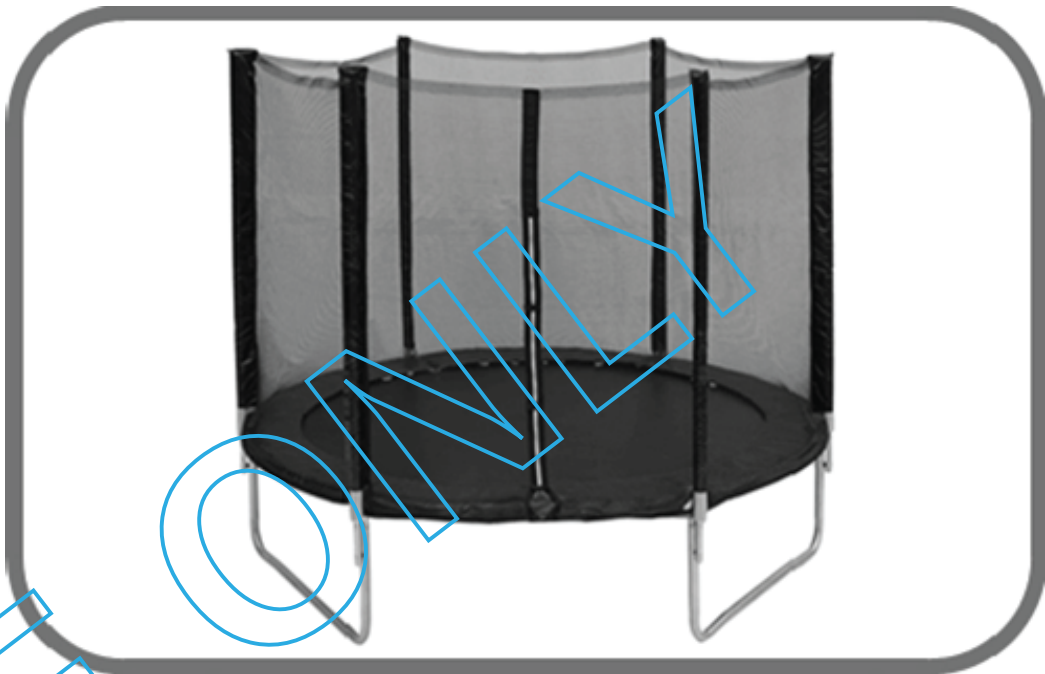

After the zip of the entrance is close and all the entrance hooks fastened, please check if all of the screws and quick clamps are fastened correctly. Now the trampoline assembly is complete.

## Recommended safe play area:

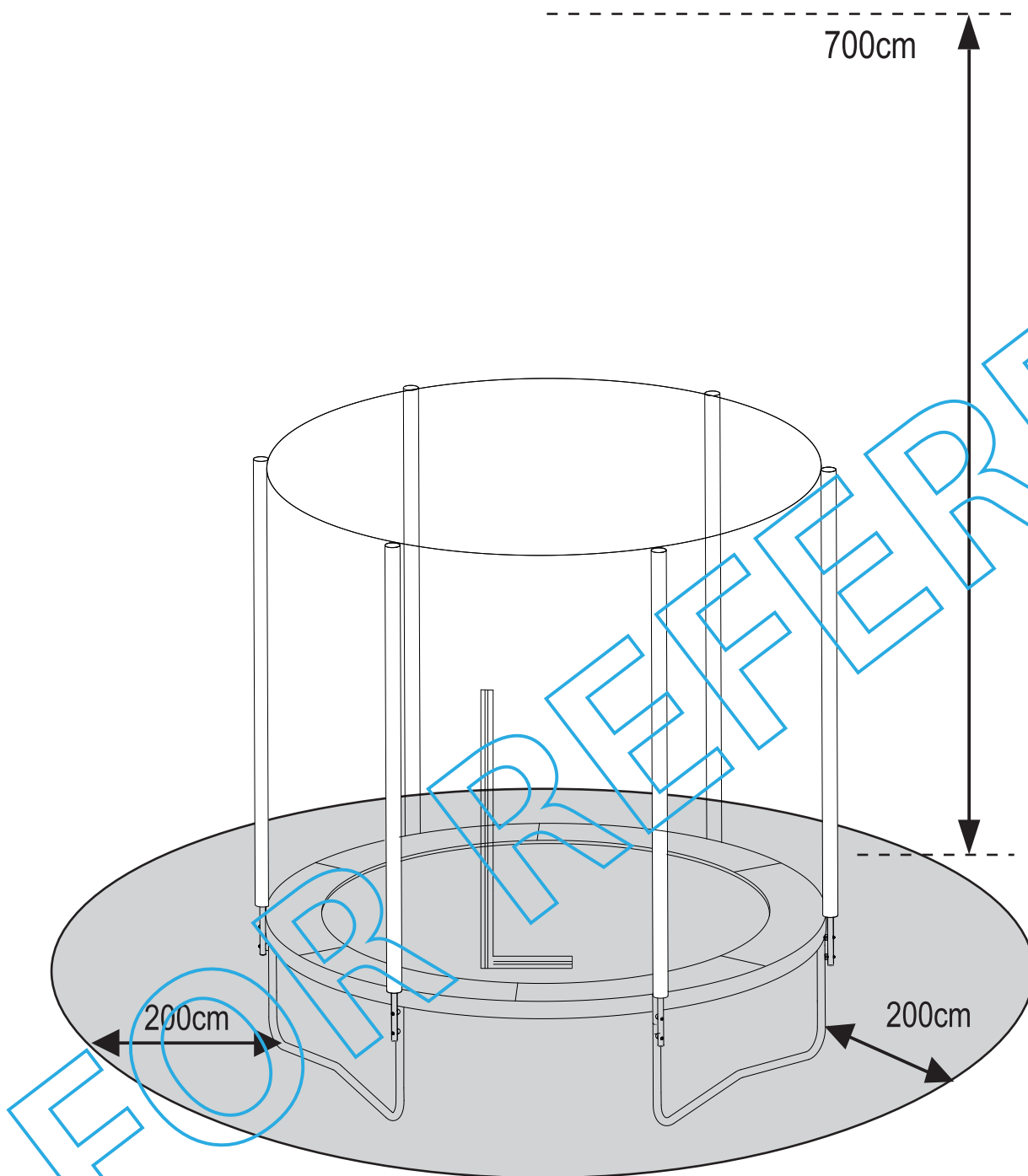

## Recommended Free Space:

The 'Safe Play Area' refers to the zone extending 200cm (2 metres) beyond the product on all sides and 700cm (7 metres) above the ground. The 'Safe Play Area' must be free from any structures, landscaping, trees and branches, rocks, wires, sprinkler heads and other similar obstacles for safe play. Children can be seriously injured running or colliding into such obstacles.

# TESTING THE TRAMPOLINE

**After assembling the trampoline, it is important that you perform the following safety checks:**

## **Trampoline Safety Checks:**

- Using a screw driver, check if all the screws are tightly secured.
- Look underneath the trampoline and check all the springs are hooked securely to the frame and triangle rings.
- Move the trampoline around and check the sturdiness of the frame.
- Using your two hands, put your body weight on one section of the trampoline and release to check that the floor is even.
- Inspect the cover pads and check if they completely cover the springs and frame.
- Make sure the strings of the pads are tied securely.

## **Enclosure Net Safety Checks:**

- Hold onto pole net jacked and check that all the enclosure poles are sturdy by shaking it.
- Check the for any tearing in the stitching or material.
- Check the enclosure net zipper and entrance hooks function properly.
- Check to see if all safety enclosure hooks are attached to the triangle ring underneath the trampoline

Once all the checks are performed and the trampoline has passed all the initial test (above), then your trampoline have one person test the trampoline by jumping on the center continuously for 5 minutes. If the trampoline feels sturdy then your trampoline passes the test. Congratulations, you have completed the trampoline assembly! Remember to abide by all the safety rules. Have fun, play safe...