

**EUROPA - M08610-02**  
**FOR CHILDREN AGED 3 TO 10 YEARS**

**SAFETY GUIDELINES**

**Warnings**

Only for domestic use. This product has not been designed for commercial use in play centers, nurseries etc.  
Only suitable for outdoor use.  
Not for children with a body weight over 45kg. Only one child per seat at any one time.  
The total weight on the product at any one time must not exceed 145kg.  
Not for children under 3 years due to small component which may cause choking hazard.

This equipment must be assembled and checked by an adult. Two adults may be required to assemble this product. Adult supervision is required at all times.  
Check all nuts, bolts and fittings for tightness and tighten if required.  
Check swing seats, chain, ropes and other means of attachments relevant to your product for evidence of deterioration. Replace when required in accordance with the manufacturers instructions if necessary.  
Place the product on level surface at least 2 metres from any structure or obstruction such as a fence, garage, house, wall, overhanging branches, laundry line or electrical wires.  
The items MUST be anchored firmly into the ground.  
DO NOT install the product over concrete, asphalt or any hard surface.  
DO NOT orientate the product directly towards the sun.  
Leave all fittings finger tight until assembly is complete, for ease of construction. Then tighten firmly. Children should not wear cycle helmets whilst on this equipment.  
Do not allow children to stand on any swing seats, glider seats or slide chutes relevant to your product.  
Do not allow the children to jump or climb off any moving equipment.  
Do not twist swing ropes or wrap them over the top bar.  
Do not allow loose, hooded or baggy clothes to be worn as children can get trapped and may be unable to free themselves. Do not allow children to climb on parts of this equipment not intended for this purpose.  
Do not allow children to wander into the play area whilst the equipment is in use.  
Do not allow children to slide head first down the chute, walk up the chute or jump or climb off the chute.  
Glider and swings must not exceed an angle of 60 degrees from the ground.  
Regularly check the item for wear and damage, removing the item from use when necessary until replacement parts are fitted.  
Failure to assemble and maintain this item as per instruction may cause injury to the user.  
The minimum clearance between the swing seat and ground level should be 350mm.  
Please contact our customer services department if you have any problems.  
Inspect all parts of this product every 6 months following purchase. If any parts look worn or you find any problems, please contact us for replacements and do not use product until problem has been corrected. Hedstrom recommends replacing the plastic swing rope clamps every 2 years even if there is no sign of deterioration.  
Do not modify this item.  
Please keep the instructions in a safe place for future reference.  
Conforms to EN71

Made in China to European Standards

11/2021 ISSUE1

**IMPORTANT:** Make sure you read the safety notice on the front page and always supervise children while they are playing on the equipment. Once assembly is completed carefully check equipment. In the unlikely event that you do find any problems, please contact us. Do not allow children to use this product until the problem has been corrected.

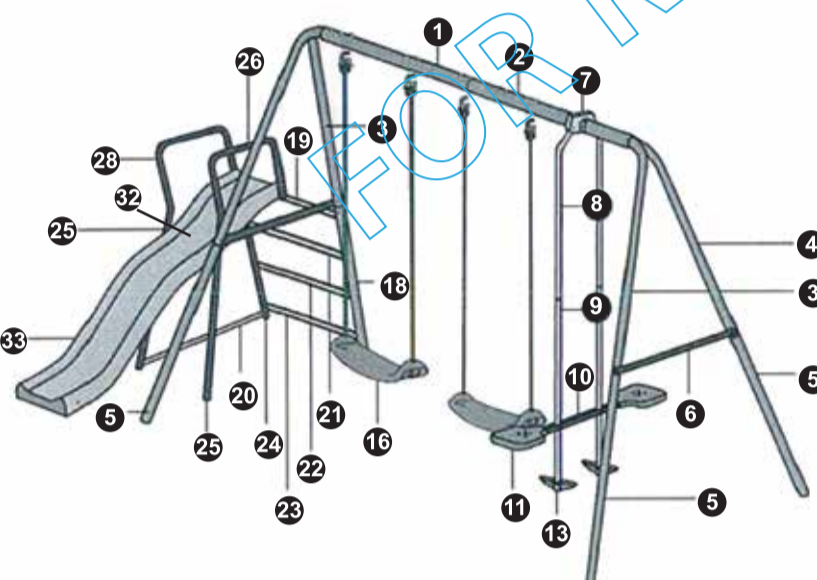

**STEP 1**  
Frame & Swing Assembly

- F1** M8 BOLT 59mm (x2)
- 17** ALLEN KEY (x1)
- 14** SPANNER (x1)

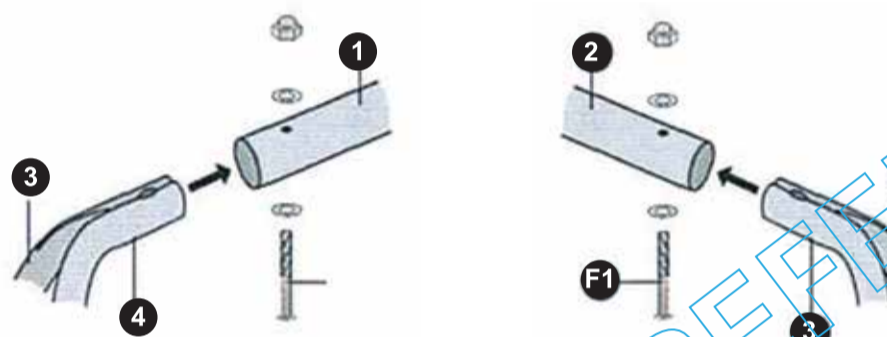

**STEP 2**  
Glider Assembly

- G1** M6 BOLT 47mm (x2)
- G2** M8 BOLT 43mm (x2)
- G8** THIN PLASTIC SPACER (x4)

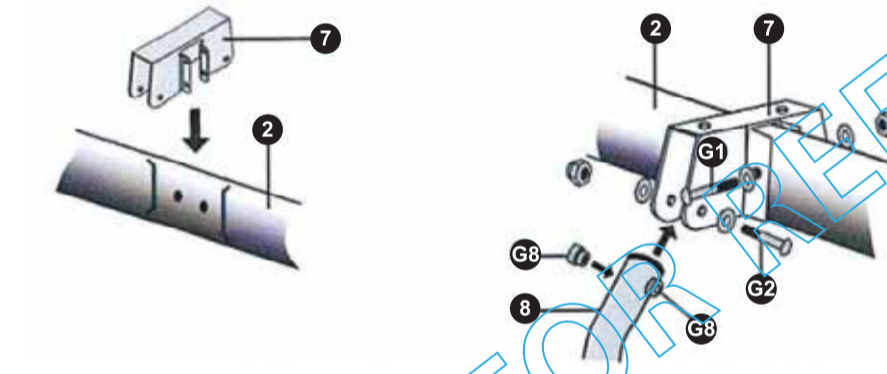

- G6** M6 BOLT 35mm (x4)

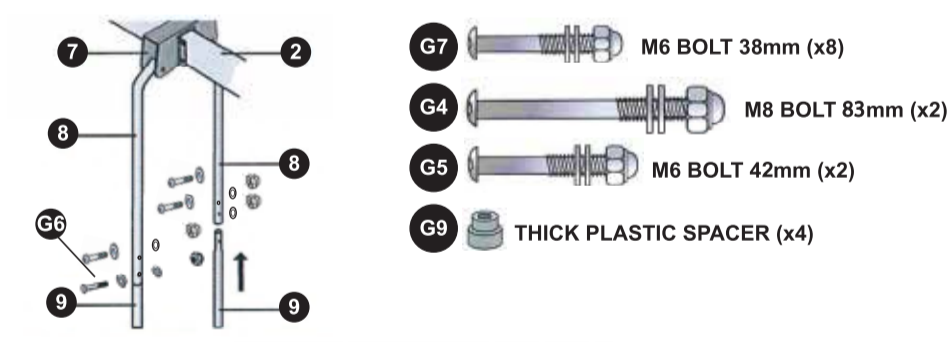

• Assemble seats (11) and attach to seat tubes (10) before tightening bolts (G4)

**STEP 3**  
Assembly Of The Bracket Onto The Slide

- F1** M6 BOLT 17mm x 3
- F2** M6 BOLT 66mm x 2

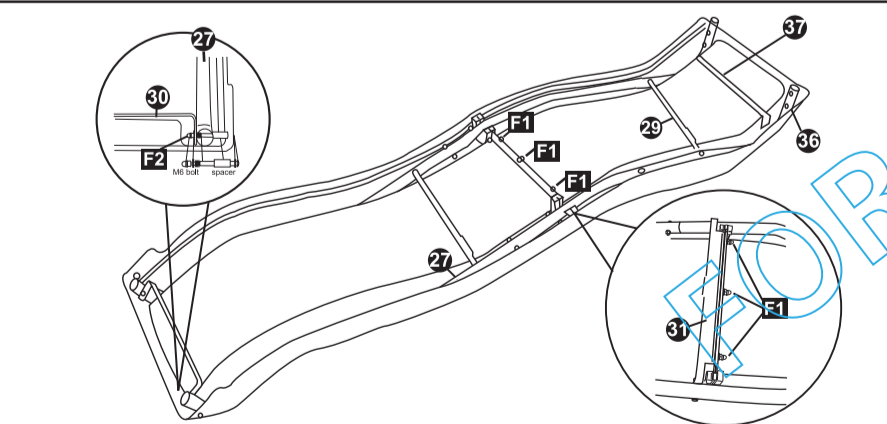

**STEP 4**  
Wavy Chute Assembly Continued

- C2** M6 BOLT 52mm (x4)
- C4** M6 BOLT 40mm (x2)
- C3** M6 BOLT 40mm (x3)
- C5** M6 BOLT 58mm (x2)
- C6** M6 BOLT 62mm (x4)

Please Note: Top ladder (19) rung is to be fitted behind ladder handle (28) and bottom leg (18)

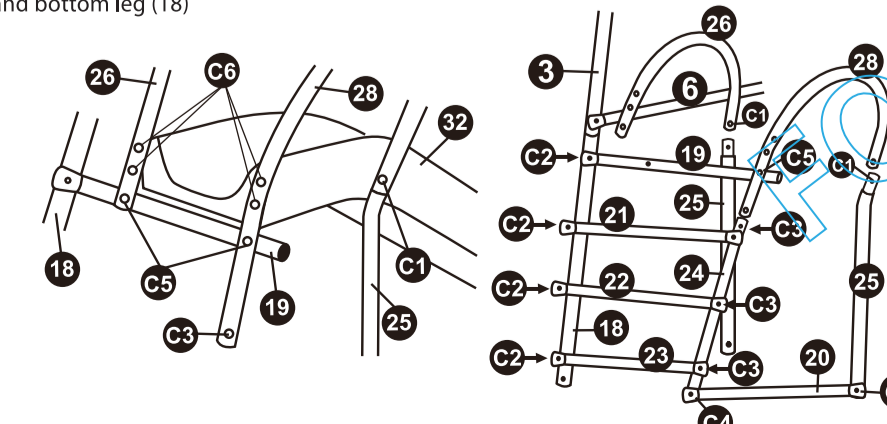

• Please assemble tube 20 last  
• Leave the bolts loose until the chute is assembled to the ladder frame, to ease construction, then tighten firmly

**SWING PARTS LIST**

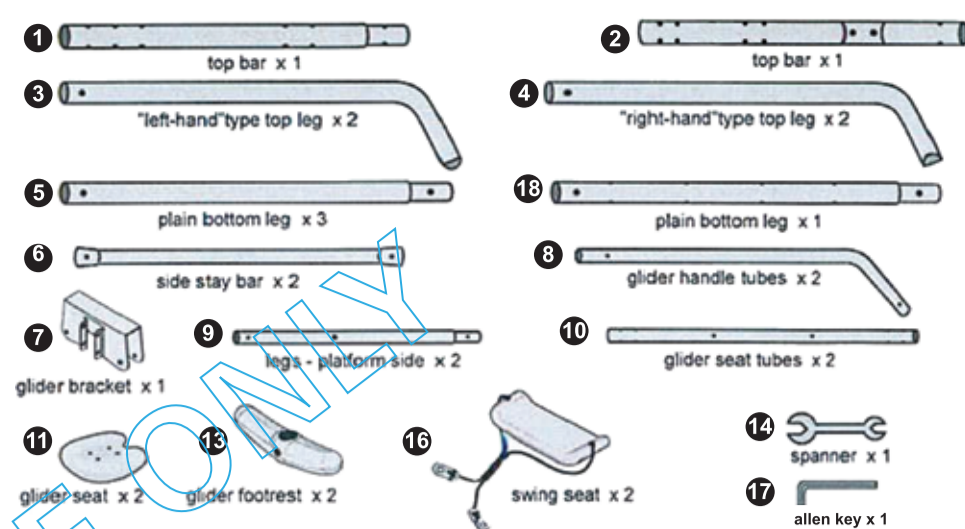

**SLIDE PARTS LIST**

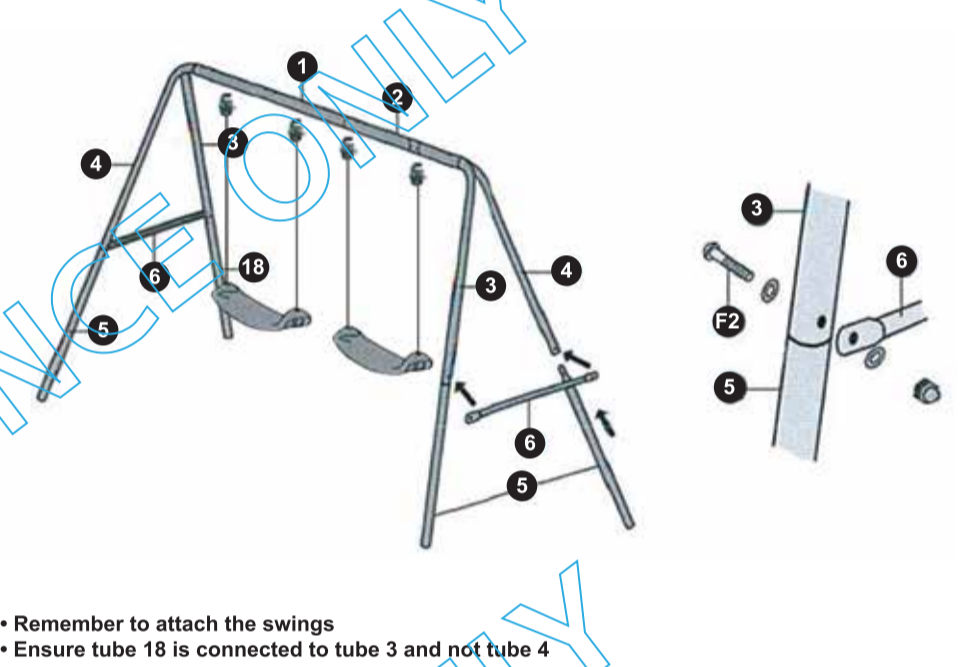
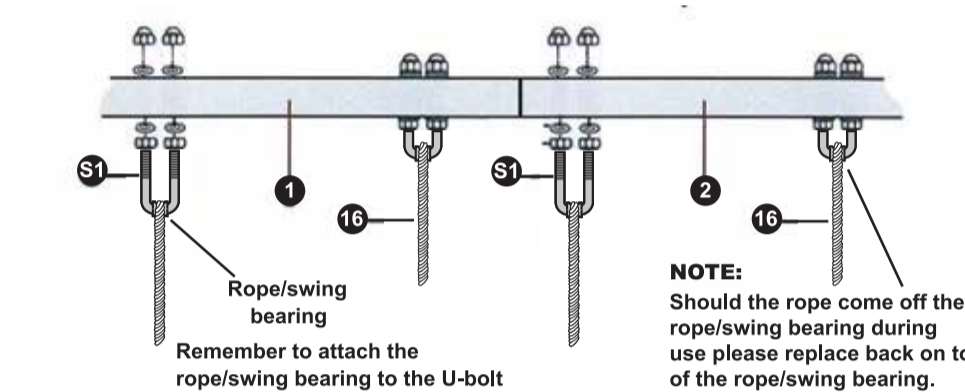
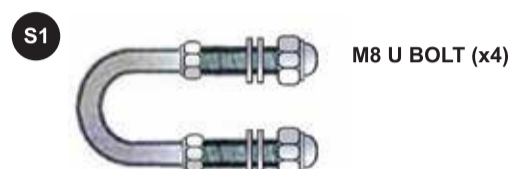
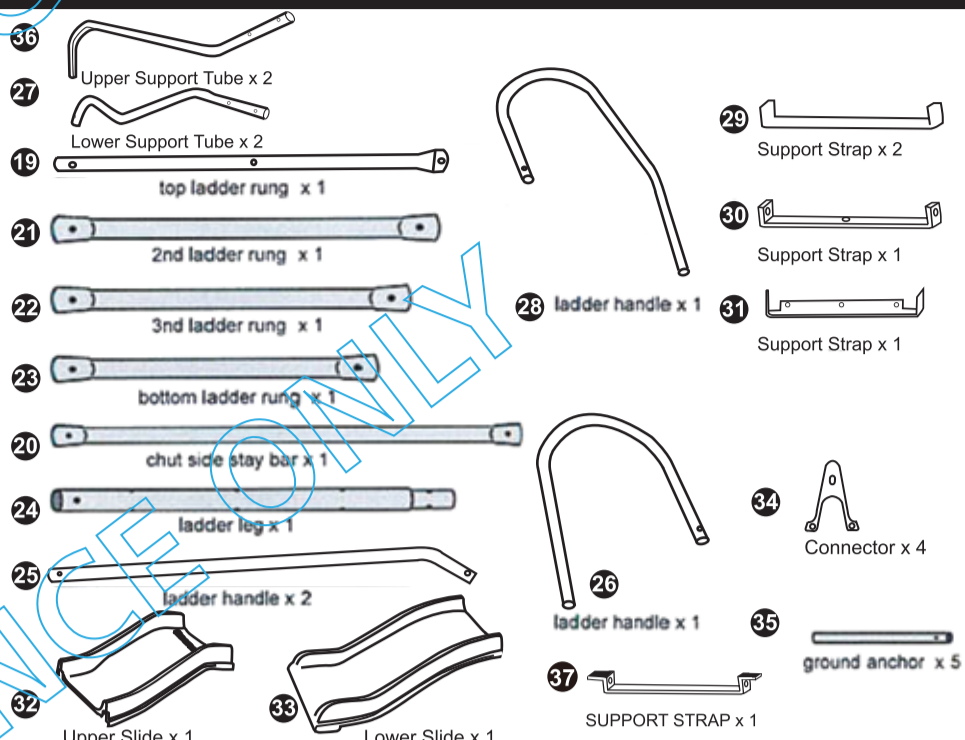

**STEP 3**  
Slide Chute Assembly

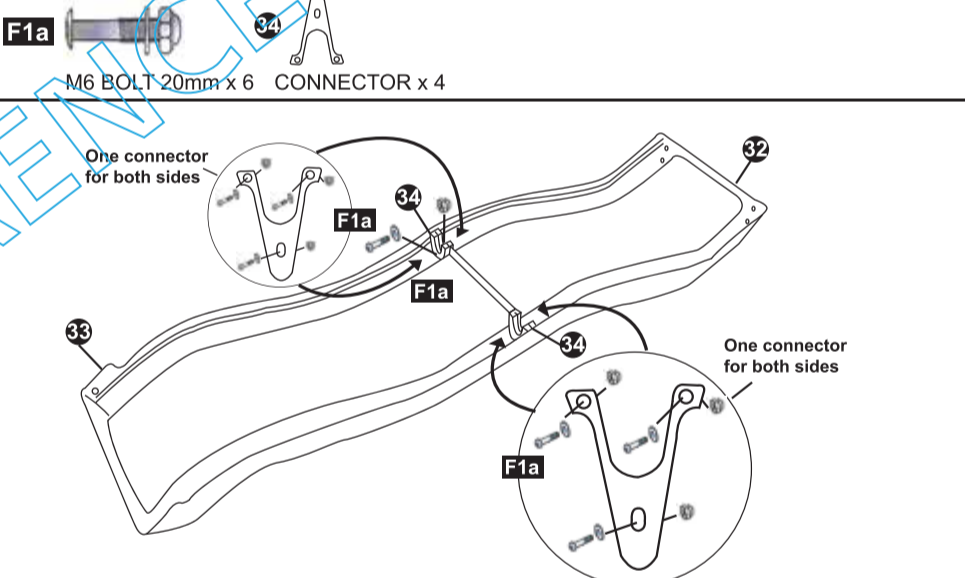

**Bracket Assembly**

- F3** M6 BOLT 35mm (x10)

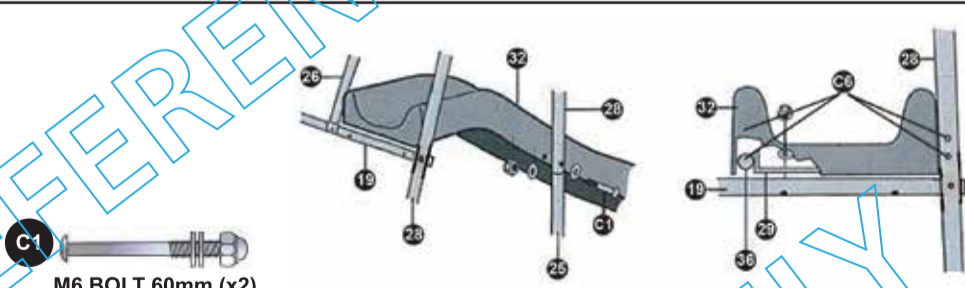
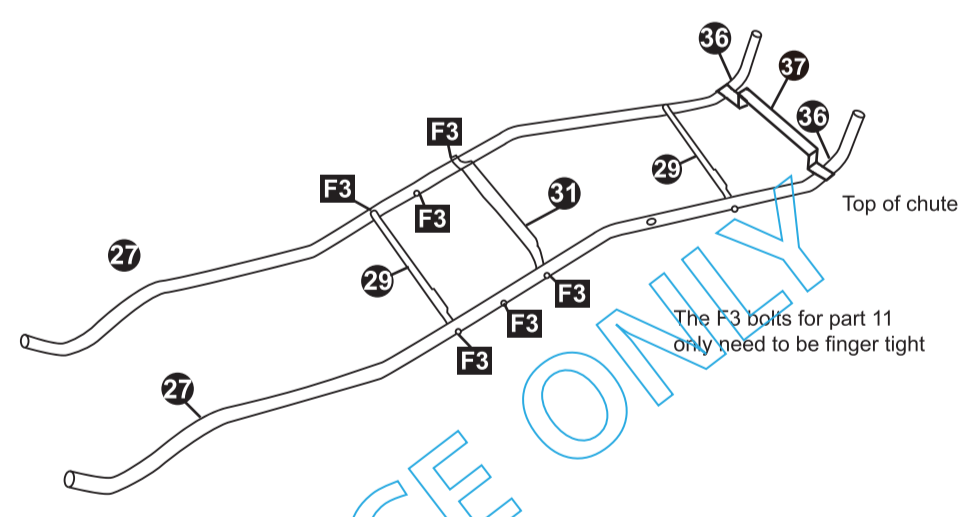

**STEP 5**  
Anchoring the Gym to the ground

**IMPORTANT:** For safety reasons this gym MUST be anchored and concreted into the ground. If you are uncertain about this procedure, telephone our helpline number.

- P1** M6 BOLT 60mm (x4)
- P2** M6 BOLT 47mm (x1)

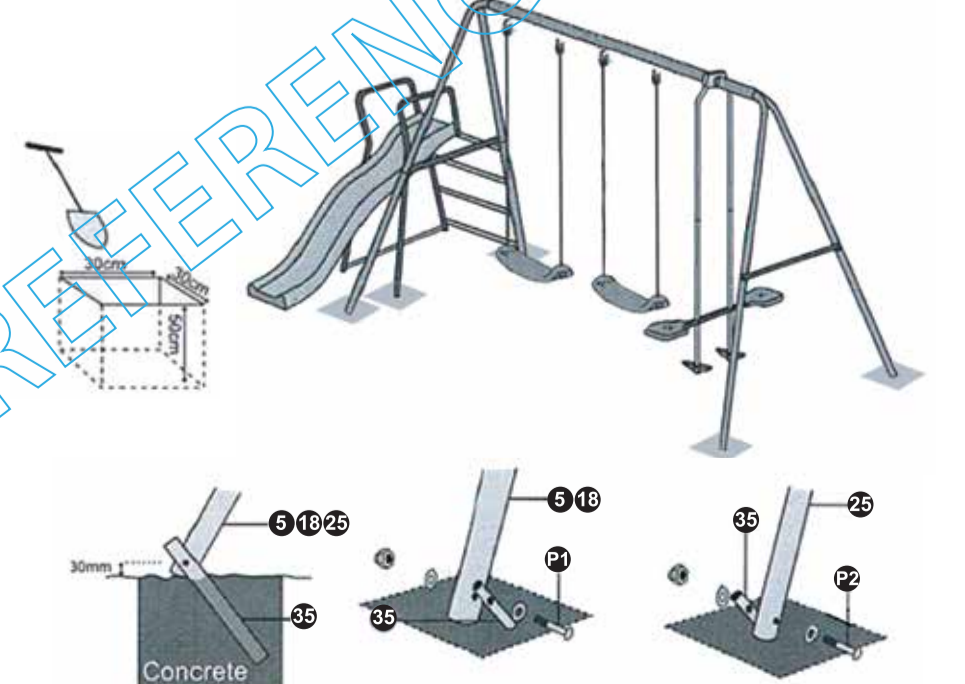

MV Sports & Leisure Ltd.  
35 Tameside Drive  
Castle Bromwich  
Birmingham B35 7AG  
United Kingdom  
email: info@mvsports.com  
www.mvsports.com

**CUSTOMER SERVICES**  
MV has taken great care to ensure that this item has reached you in good condition. Should you have a query, please contact customer.services@mvsports.com where your query will be dealt with promptly. Alternatively, you can call on 0121 748 8017.

