

ALPHA - M08859

FOR CHILDREN AGED 3 TO 10 YEARS

SAFETY GUIDELINES

Warnings

Only for domestic use. This product has not been designed for commercial use in play centres, nurseries etc.

Only suitable for outdoor use.

Not for children with a body weight over 45kg. Only one child per seat at any one time.

The total weight on the product at any one time must not exceed 145kg.

Not for children under 3 years due to small component which may cause choking hazard.

This equipment must be assembled and checked by an adult. Two adults may be required to assemble this product. Adult supervision is required at all times.

Before use please check all bolts are tight, secure and intact.

Check all coverings for bolts and sharp edges and replace when required.

Check swing seats, chain, ropes and other means of attachments if relevant to your product for evidence of deterioration. Replace when required in accordance with the manufacturers instructions if necessary.

Place the product on level surface at least 2 metres from any structure or obstruction such as a fence, garage, house, wall, overhanging branches, laundry line or electrical wires.

The items MUST be anchored firmly into the ground.

DO NOT install the product over concrete, asphalt or any hard surface.

DO NOT orientate the product directly towards the sun.

Leave all fittings finger tight until assembly is complete, for ease of construction. Then tighten firmly.

Children should not wear cycle helmets whilst on this equipment.

Do not allow children to stand on any swing seats, glider seats or slide chutes relevant to your product.

Do not allow the children to jump or climb off any moving equipment.

Do not twist swing ropes or wrap them over the top bar.

Do not allow loose, hooded or baggy clothes to be worn as children can get trapped and may be unable to free themselves.

Do not allow children to climb on parts of this equipment intended for this purpose.

Do not allow children to wander into the play area whilst the equipment is in use.

Do not allow children to slide head first down the chute, walk up the chute or jump or climb off the chute.

Glider and swings must not exceed an angle of 60 degrees from the ground.

Regularly check the item for wear and damage, removing the item from use when necessary until replacement parts are fitted.

Failure to assemble and maintain this item as per instruction may cause injury to the user.

The minimum clearance between the swing and ground level should be 350mm.

Please contact our customer services department if you have any problems. Do not modify this item.

Please keep the instructions in a safe place for future reference.

Made in China to European Standards.

Conforms to EN71

FRAME & CLIMBING FRAME



top bar a (x1)



top bar b (x1)



bottom leg (x1)



bottom leg (x1)



bottom leg (x2)

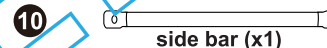

side bar (x1)

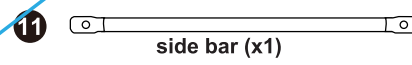

side bar (x1)

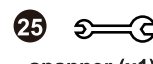

spanner (x1)



allen key (x1)



top leg (x1)



top leg (x1)

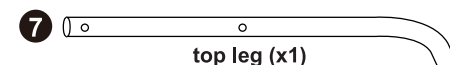

top leg (x1)



top leg (x1)

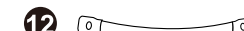

ladder (x1)



ladder (x1)



ladder (x1)

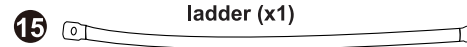

ladder (x1)

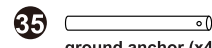

ground anchor (x4)

FABRIC GOALS & SWINGS

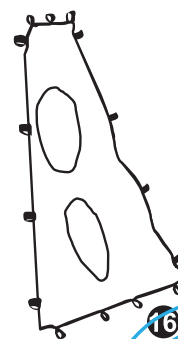

16 Hoop & Loop Attachment

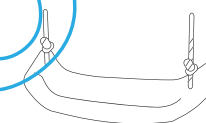

17 swing seat (x2)

IMPORTANT: Make sure you read the safety notice on the front page and always supervise children while they are playing on the equipment. Once assembly is completed carefully check equipment. In the unlikely event that you do find any problems, please contact us. Do not allow children to use this product until the problem has been corrected.

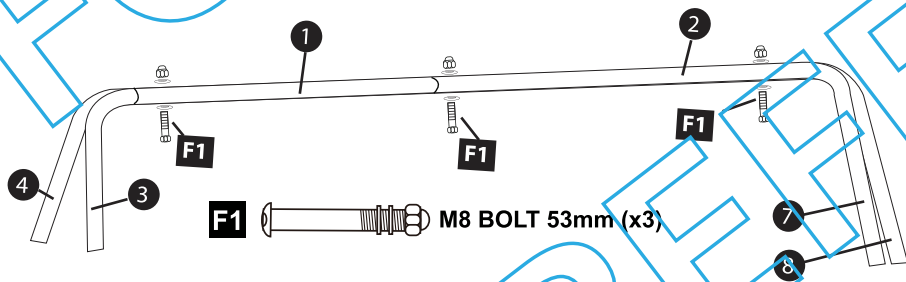
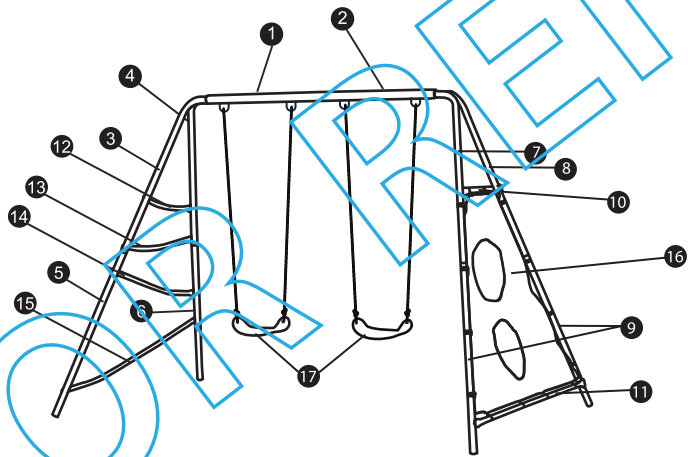

F1 M8 BOLT 53mm (x3)

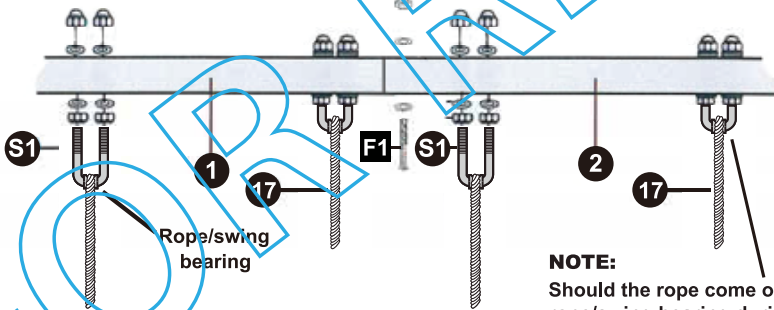

Remember to attach the rope/swing bearing to the U-bolt

NOTE: Should the rope come off the rope/swing bearing during use please replace back on of the rope/swing bearing

S1
M8 U BOLT (x4)



STEP 2

Anchoring the gym to the ground

IMPORTANT: For safety reasons this gym **MUST** be anchored and concreted into the ground. If you are uncertain about this procedure, telephone our helpline number.

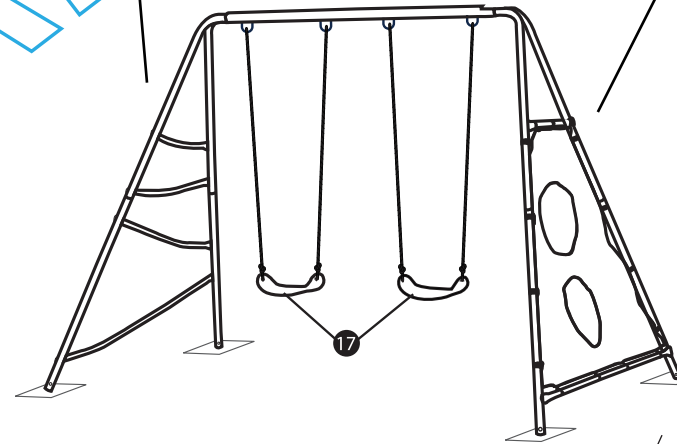
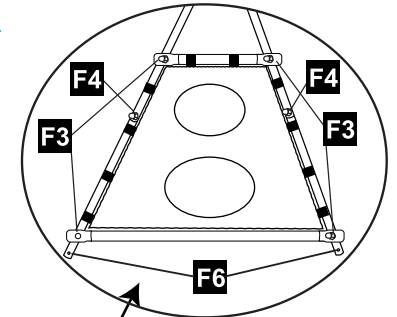
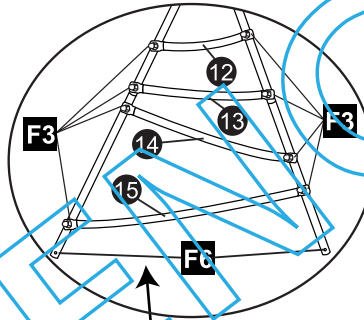

- F3** M6 BOLT 50mm (x12)
- F4** M6 BOLT 42mm (x2)
- F6** M6 BOLT 58mm (x4)

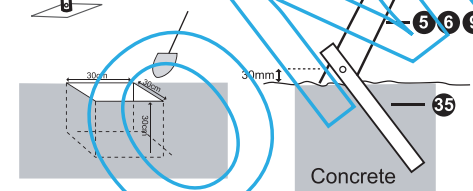

MV Sports & Leisure Ltd.
35 Tameside Drive
Castle Bromwich
Birmingham B35 7AG
United Kingdom
email: info@mvsports.com
www.mvsports.com

CUSTOMER SERVICES

MV has taken great care to ensure that this item has reached you in good condition. Should you have a query, please contact customer.services@mvsports.com where your query will be dealt with promptly. Alternatively, you can call on 0121 748 3017.



Vulcan Consulting
EU Authorised Representative, The Merrion
Buildings - Iconic offices, 18-20 Merrion
Street, Dublin 2, D02 XH98, Ireland.

This mark denotes compliance with the standards laid down by the E.C. (European Community). It is in your best interest to keep a note of our name and address for future reference. If you have any complaints or find this product to be faulty, in order to avoid any delay, please contact the distributor at the address shown.